

Figures

FIG. 1 — Line-Mounted GridLeak Sensor Node (Exterior Overview)

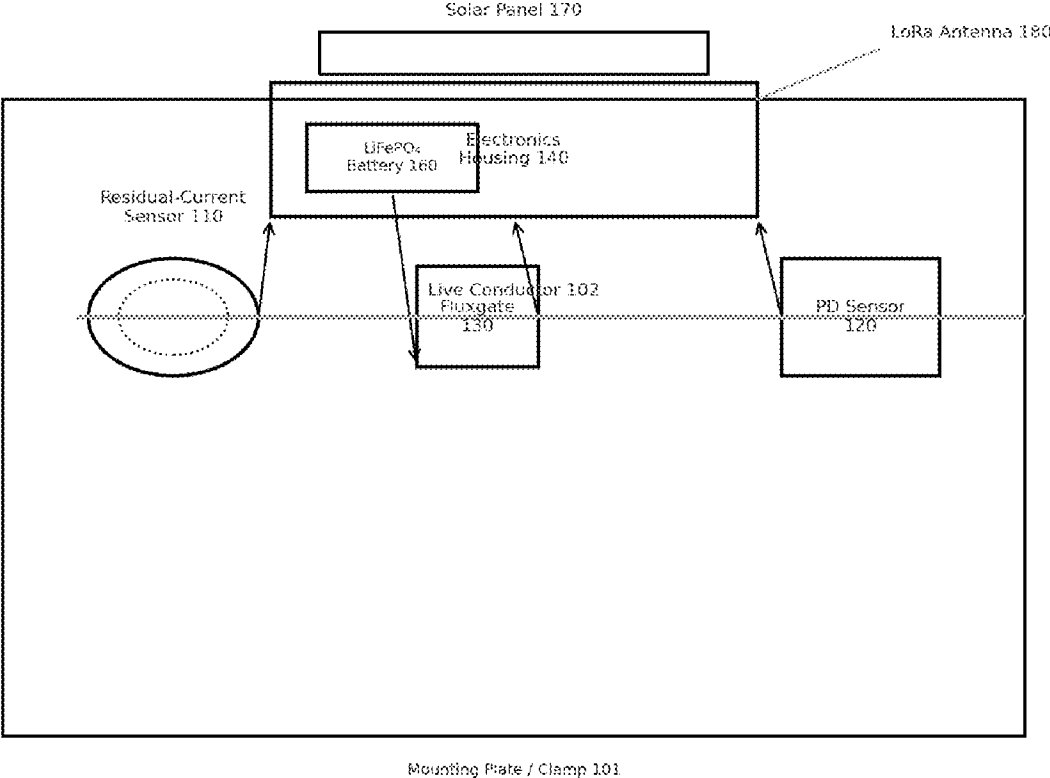

FIG. 2 — Isometric Exterior View of Sensor Node

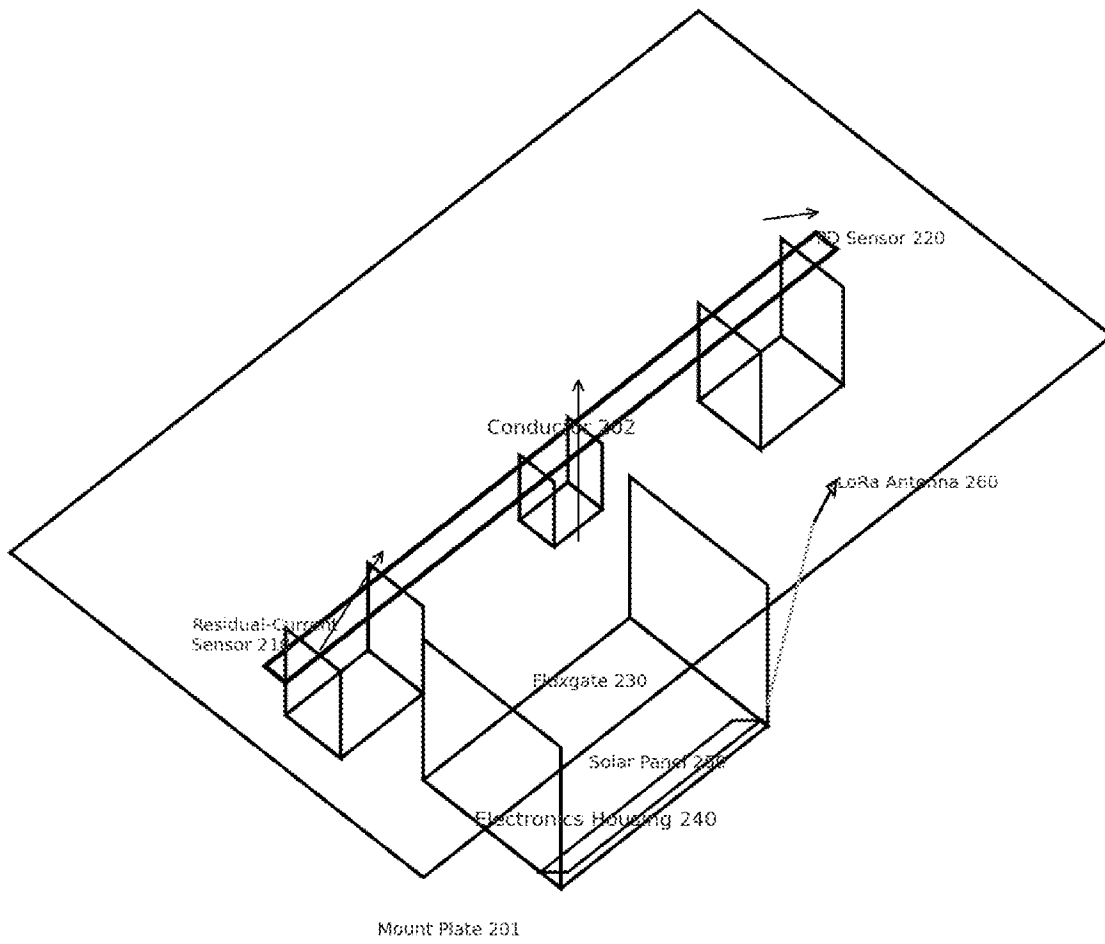

FIG. 3 — Dual-Source Power Harvesting & Management Subsystem

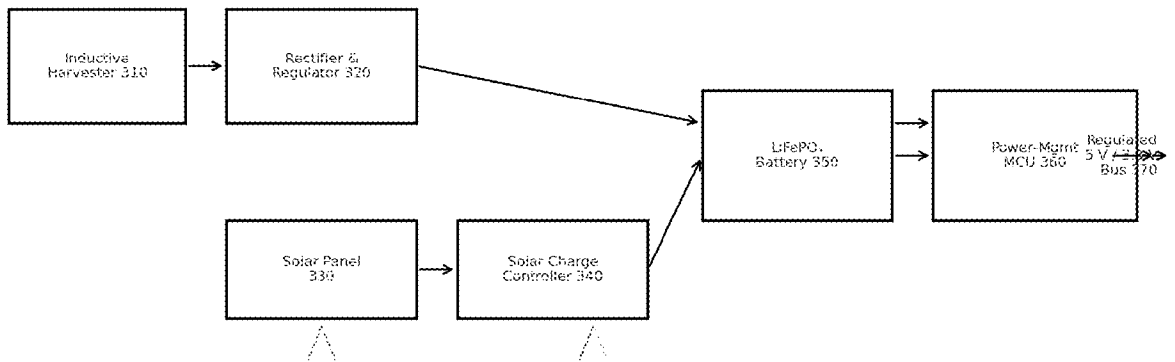
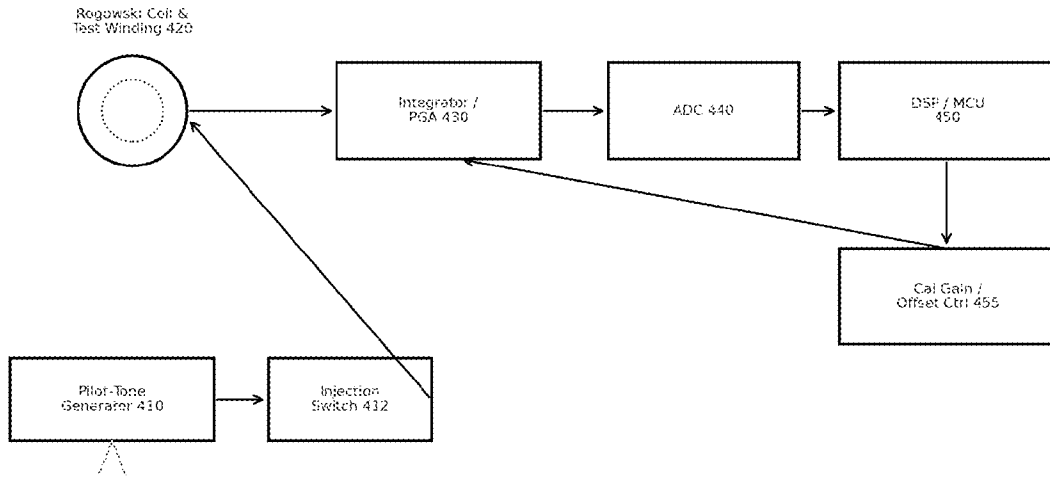

FIG. 4 — Pilot-Tone Self-Calibration Loop



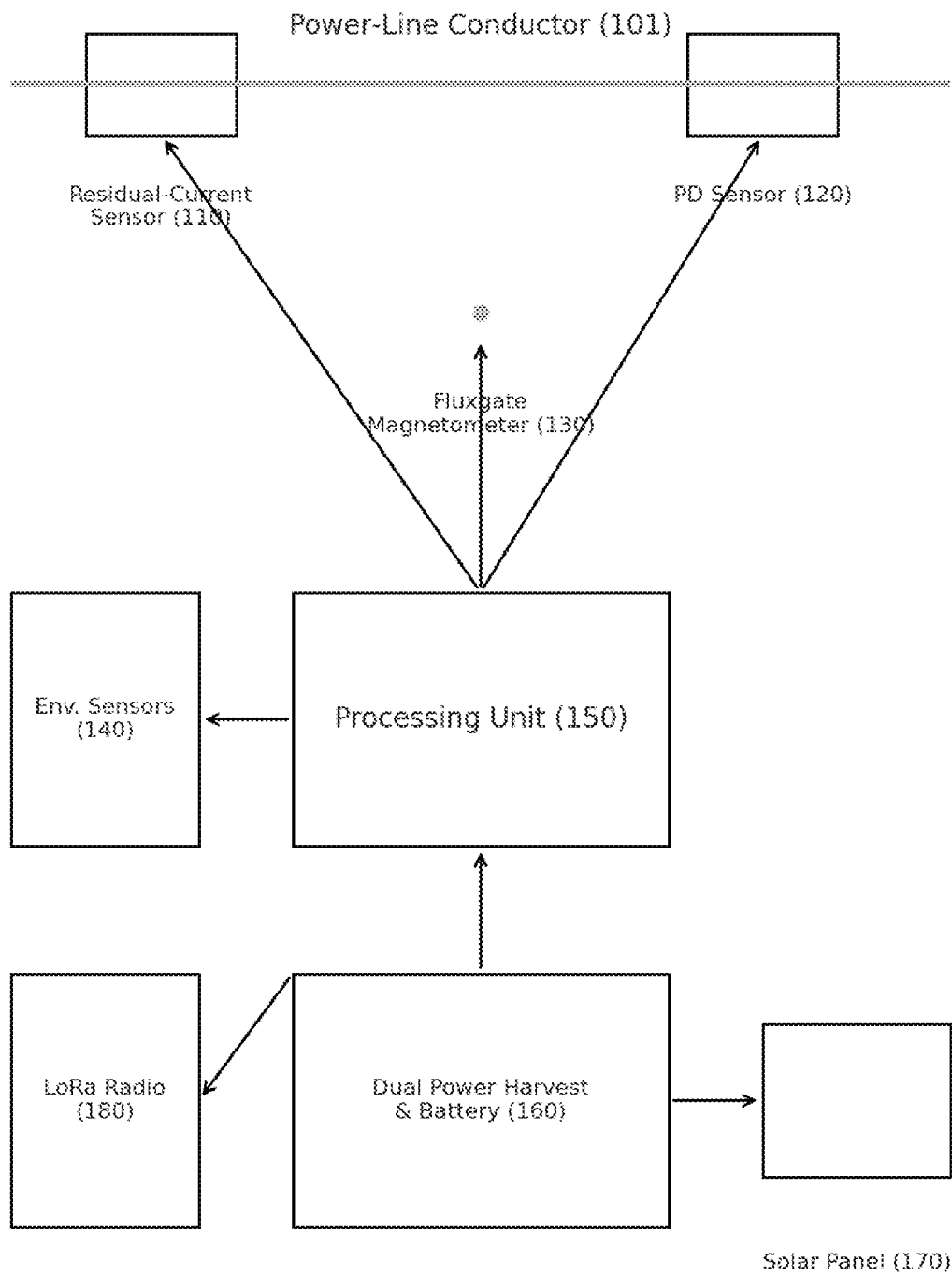

FIG. 5 — Fluxgate DC-Drift Detection & Kalman Estimator Path

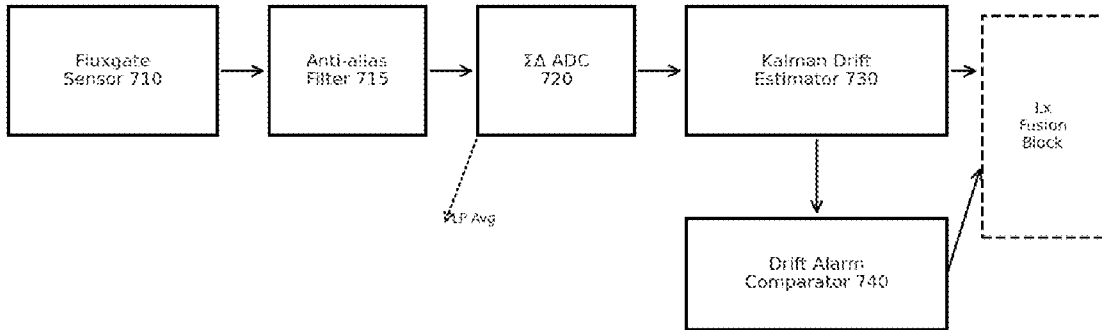

FIG. 6 — Phase-Resolved PD Map Generation & LoRa Compression Path

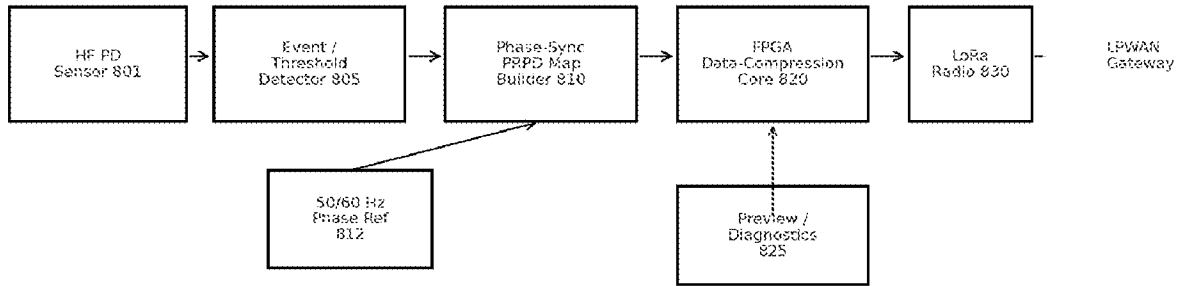

FIG. 7A — Sensor-Fusion Architecture for Leak-Index Computation

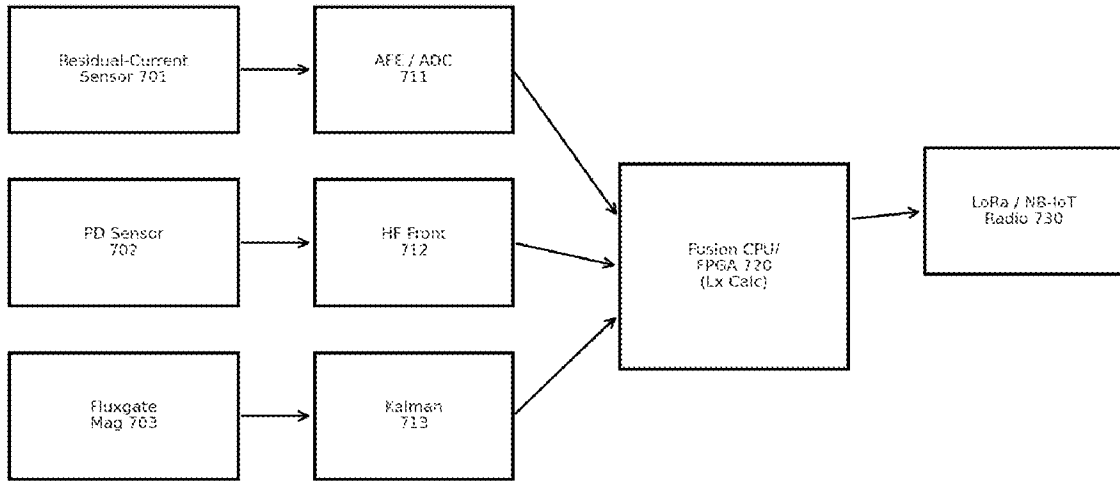
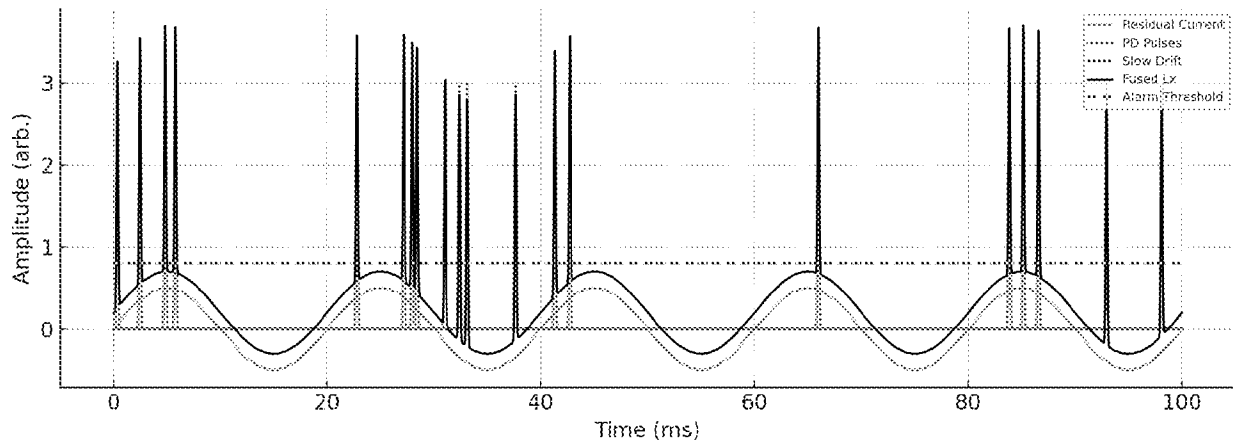

FIG. 7B — Contributions of Sensor Channels to Fused Lx



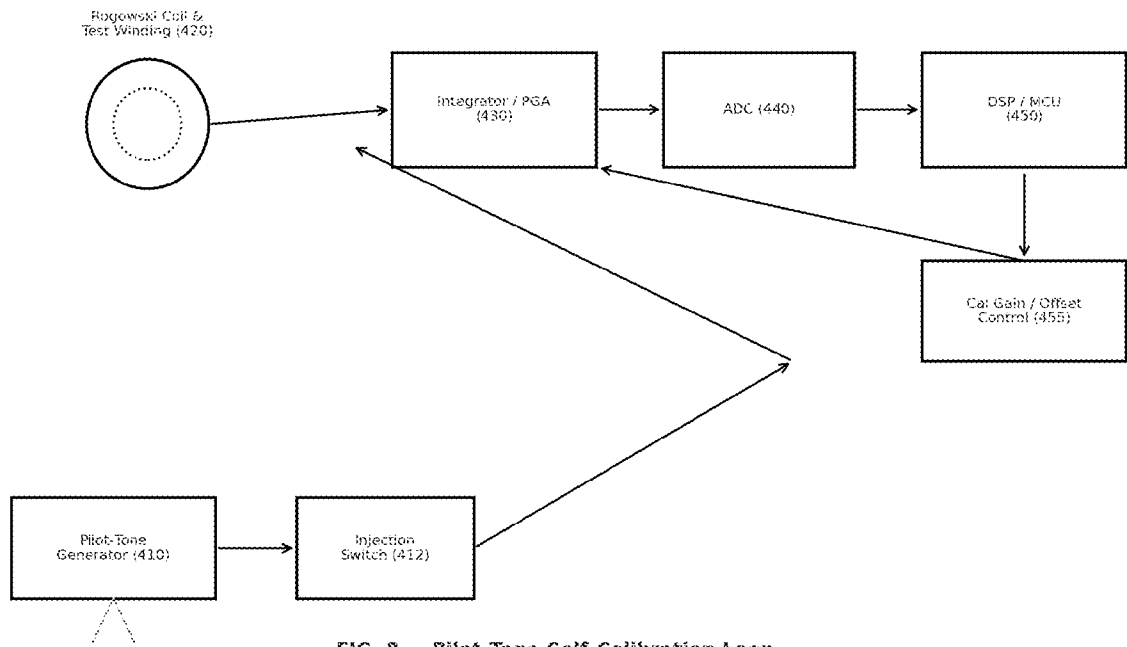

FIG. 8 — Pilot-Tone Self-Calibration Loop

FIG. 9 — PRPD Processing & Compression Flow

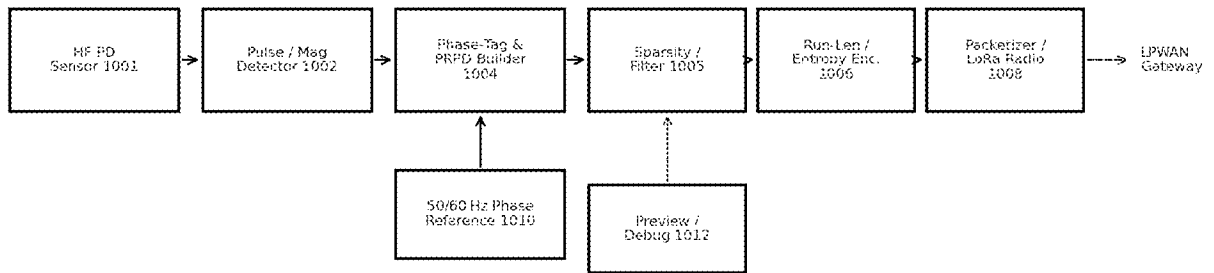

FIG. 10 — Environmental Weighting & Adaptive Threshold Path

